

PIRANHA III

TUNGSTEN ELECTRODE GRINDER
SAFE • COMPACT • AFFORDABLE



MADE IN AMERICA

HEAVY DUTY DEDICATED TUNGSTEN GRINDER
DESIGNED FOR CONTINUOUS GRINDING OF .040" TO 3/16" (1.0MM-4.8MM)

Safety

Enclosed grinding area captures Tungsten dust for easy disposal.

Weld Quality

20 Ra surface finish improves Tungsten life, arc starting, arc stability and produces consistent weld penetration.

Productivity

Correctly and consistently Diamond grind your Tungsten Electrode longitudinally, in less than 30 seconds.

Value

The PIRANHA III Diamond grinds, flats and notches your Tungsten economically.

DIAMOND GROUND PRODUCTS

Visit our web site: www.diamondground.com



PIRANHA III

Tungsten Electrode Grinder

FEATURES

- Easy set-up, optimal consistency and near-perfect repeatability.
- Compact, durable and solid design with no vibration.
- Longitudinal 20 RA grinding for maximum arc starting, arc stability, electrode life & weld penetration.
- Universal collet arm for 6 electrode sizes - .040" (1.0mm), 1/16" (1.6mm), 3/32" (2.4mm), 1/8" (3.2mm), 5/32" (4.0mm) & 3/16" (4.8mm) - with no equipment changes.
- Included angle scale for angles from 10° - 60°
- Precision tip flat gauge & depth adjustment stop ensures exact tungsten points every time - enabling consistent, repeatable arc performance and welding output.
- Containment baffle to keep dust inside the grinder housing, for safety and easy disposal.
- Tip flat block for square end grinding and removing bad tips.
- Electrode notching station for simple cut-off.
- Detailed manual for valuable engineering data and welding recommendations.

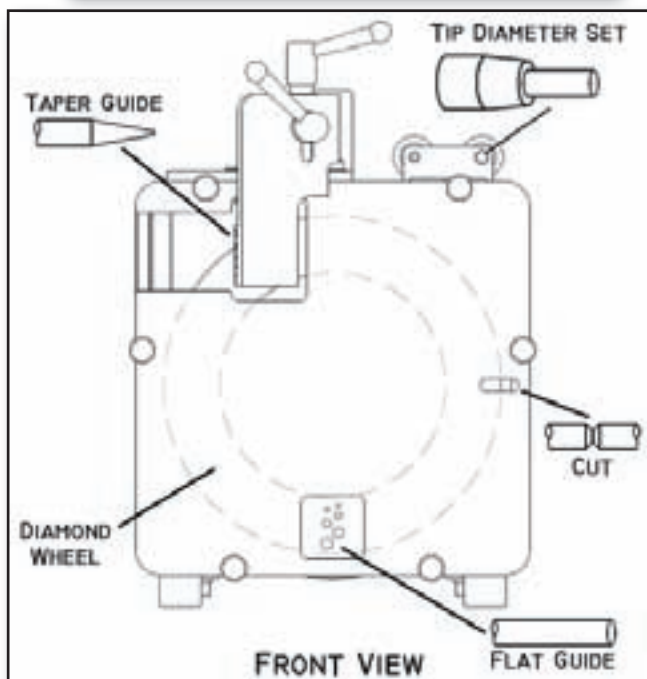
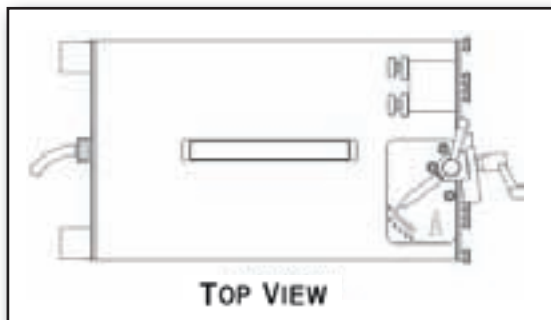

ADDITIONAL PRODUCTS

- **Piranha II** - Compact/Precision tungsten grinder .040"- 3/32" (1.0 - 2.4mm).
- **DGP-II** - Full feature tungsten grinder that grinds, flats and precisely cuts the tungsten to a precise length.
- **Pre Ground Electrodes** - CNC manufactured high tolerance electrodes for Orbital and Automatic Tig and Plasma welding.
- **Premium Tungsten** - Thoriated, Lanthanated, Ceriated, Zirconiated, Tri-Mix(tm), Cryo-T, Pure & specialty materials.

SPECIFICATIONS

Range of Included Angle:	10° - 60°
Electrode Diameters:	.040"(1.0mm), 1/16" (1.6mm), 3/32" (2.4mm), 1/8" (3.2mm) , 5/32" (4.0mm) & 3/16" (4.8mm)
Minimum Electrode Length:	1.75" (44.5mm)
Voltage:	100/120 VAC, 50/60Hz, 220v
Power Consumption:	500 Watts
Motor:	1/10 hp, 3000rpm, 2.5 amps
Length:	13.5" (342mm)
Width:	7.0" (177mm)
Height:	9.5 (240mm)
Weight:	46 lbs (20.87kg)

BENEFITS

- **Safety:** Enclosed grinding area captures Tungsten dust for easy disposal.
- **Weld Quality:** 20 Ra surface finish improves Tungsten life, arc starting, arc stability and produces consistent weld penetration.
- **Productivity:** Longitudinally Diamond grind your Tungsten electrode in less than 30 seconds correctly and consistently.
- **Value:** The PIRANHA III Diamond grinds, flats and notches your Tungsten economically.

DIAMOND GROUND PRODUCTS, INC.

2550 Azurite Circle Newbury Park CA 91320
Phone (805) 498-3837 • FAX (805) 498-9347

Email: sales@diamondground.com

Visit our website: www.diamondground.com

